

PRODUCT SPECIFICATION

| | |
|------|------------|
| Sez. | UTO ASQ |
| Pag. | 1 |
| Rev. | |

Title Grader cutting Edges

CURVED CUTTING EDGE

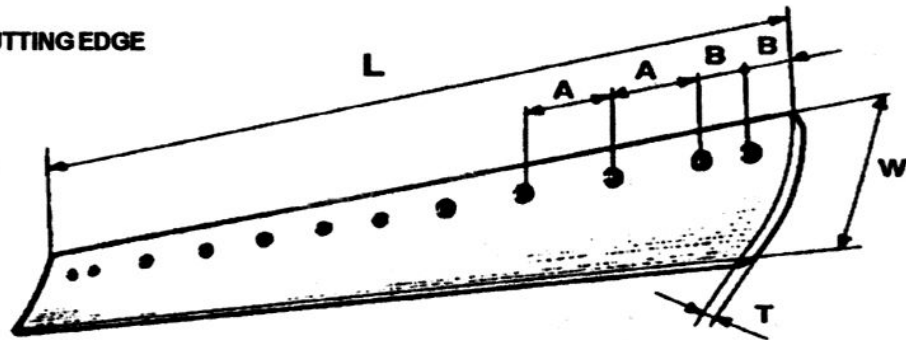

A 6' = 152,4 mm. or 12" = 304,8 mm.
B 3" = 76,2 mm.

Dimensions

| | | | | | | | |
|------------------|---|-------------|-------------|-------------|-------------|-------------|--|
| W | = | 152 | 203 | | | | |
| T | = | 16 | 19 | 25 | | | |
| L | = | 1219 | 1524 | 1828 | 2133 | 2438 | |
| Bolt-hole | = | 5/8" | 3/4" | | | | |

Type steel

MTM 75HE

Chemical composition

| C | Mn | S | P | Si | Sn | Cu | Mo | Ni | Cr | |
|------|-----|------|------|------|------|-----|------|-----|-----|--|
| 0,7 | 0,6 | 0,03 | 0,03 | 0,15 | 0,04 | 0,4 | 0,08 | 0,3 | 0,3 | |
| 0,75 | 0,8 | MAX | MAX | 0,35 | MAX | MAX | MAX | MAX | MAX | |

Mechanical Properties

| Life | Rm (N/mm) | Re (N/mm) | A (%) | Z (%) | Jominy - 20°C | HB | HRC |
|-------|---------------|---------------|----------|----------|------------------|---------|-------|
| Rough | 900 | 500 | 12 | | 8J | 240-280 | 23-30 |

Note

This steel is indicated for wear parts products.Agriculture end earthmoving machines

| | | | | |
|------------|------------|-----------|------------|---------|
| Issue date | 12-12-2003 | Last Rev. | Prev. Rev. | No.Doc. |
|------------|------------|-----------|------------|---------|

KOMATSU-GRADERS

Cutting Edges, Molboards & Overlays



**T O U G H
C O M P O N E N T S**

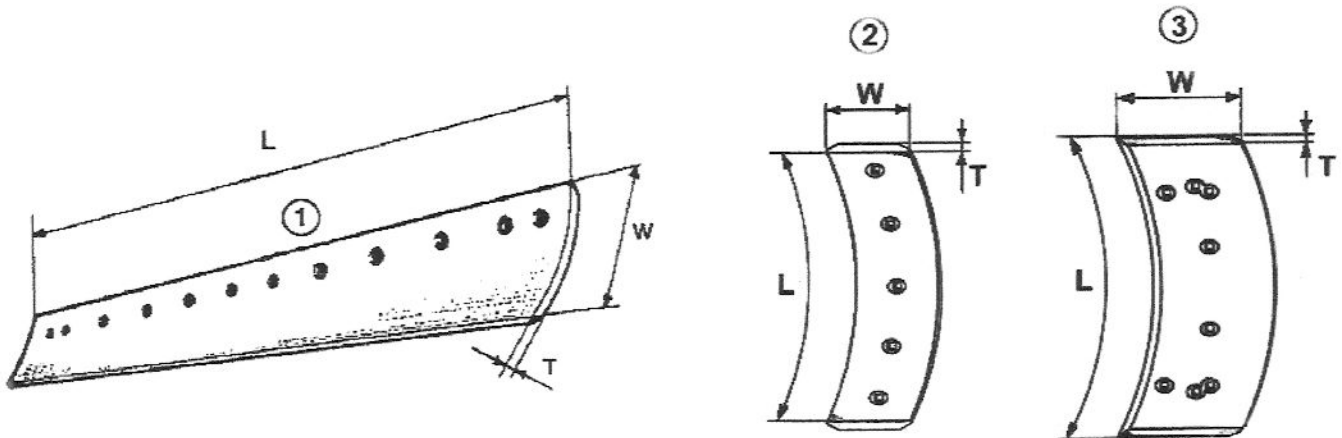

| O.E.M. Part Nr. | No Pcs | MTM Nr. | Description | Ref. | Inches | | | Millimeters | | | Nr. H. | Ø | Weight | |
|-----------------|--------|---------|------------------|------|--------|-----|-----|-------------|----|------|--------|------|--------|------|
| | | | | | W | T | L | W | T | L | | | Kg. | Lbs |
| GD200A-1 | | | | | | | | | | | | | | |
| 236-70-22120 | 1 | | C.E. Curv. Carb. | 1 | | | 7,0 | | | 2133 | | | | |
| 236-978-1151 | 2 | | C.E. Curv. Carb. | 1 | | | 4,0 | | | 1219 | | | | |
| GD22AC-1 | | | | | | | | | | | | | | |
| 236-70-22120 | | | C.E. Curv. Carb. | 1 | | | | | | | | | | |
| GD22H-1 | | | | | | | | | | | | | | |
| 237-70-12120 | | | C.E. Curv. Carb. | 1 | | | | | | | | | | |
| GD28AC-1 | | | | | | | | | | | | | | |
| 238-70-12220 | 2 | | C.E. Curv. Carb. | 1 | 6,0 | 5/8 | 5,0 | 152 | 16 | 1524 | 7 | 5/8" | 27,8 | 61,2 |
| 237-70-12120 | 2 | | C.E. Curv. Carb. | 1 | | | 5,0 | | | 1524 | 7 | 5/8" | | |
| 233-870-6120 | 2 | | C.E. Curv. Carb. | 1 | | | 5,0 | | | 1524 | 7 | 5/8" | | |
| 233-70-12450 | 2 | | C.E. Curv. Carb. | 1 | | | 5,0 | | | 1524 | 7 | 5/8" | | |
| 233-70-12141 | 2 | | C.E. Curv. Carb. | 1 | | | 5,0 | | | 1524 | 7 | 5/8" | | |
| 237-870-1130 | 1 | | Moldboard | 2 | 6,0 | 5/8 | 1,4 | 152 | 16 | 423 | 4 | 5/8" | 7,716 | 17,0 |
| 237-870-1120 | 1 | | Moldboard | 2 | 6,0 | 5/8 | 1,4 | 152 | 16 | 423 | 4 | 5/8" | 7,716 | 17,0 |
| 236-70-22360 | 2 | | | | | | | | | | | 5/8" | | |
| 232-70-12150 | 2 | | Overlay | 3 | 9,1 | 1/2 | 1,4 | 230 | 13 | 421 | 5 | 5/8" | 9,441 | 20,8 |
| 232-70-12160 | 2 | | Overlay | 3 | 9,1 | 1/2 | 1,4 | 230 | 13 | 421 | 5 | 5/8" | 9,441 | 20,8 |
| GD300A-1 | | | | | | | | | | | | | | |
| 233-870-6120 | | | C.E. Curv. Carb. | 1 | | | | | | | | | | |
| 233-70-12450 | | | C.E. Curv. Carb. | 1 | | | | | | | | | | |
| 233-70-12141 | | | C.E. Curv. Carb. | 1 | | | | | | | | | | |
| 237-870-1130 | 1 | | Moldboard | 2 | 6,0 | 5/8 | 1,4 | 152 | 16 | 423 | 4 | 5/8" | 7,716 | 17,0 |

Our parts are not original but they are interchangeable with them. The O.E.M. Part Numbers are give for reference purposes only.

KOMATSU-GRADERS

Cutting Edges, Molboards & Overlays



**T O U G H
C O M P O N E N T S**

| O.E.M. Part Nr. | No Pcs | MTM Nr. | Description | Ref. | Inches | | | Millimeters | | | Nr. H. | Ø | Weight | |
|--------------------|-----------|------------|------------------|------|--------|-----|-----|-------------|----|------|-----------|------|--------|------|
| | | | | | W | T | L | W | T | L | | | Kg. | Lbs |
| GD300A-1 | | | | | | | | | | | | | | |
| 237-870-1120 | 1 | | Moldboard | 2 | 6,0 | 5/8 | 1,4 | 152 | 16 | 423 | 4 | 5/8" | 7,716 | 17,0 |
| 236-70-22360 | 2 | | | 2 | | | | | | | | | | |
| 232-70-12150 | 1 | | Overlay | 3 | 9,1 | 1/2 | 1,4 | 230 | 13 | 421 | 5 | 5/8" | 9,441 | 20,8 |
| 232-70-12160 | 1 | | Overlay | 3 | 9,1 | 1/2 | 1,4 | 230 | 13 | 421 | 5 | 5/8" | 9,441 | 20,8 |
| GD30-5M | | | | | | | | | | | | | | |
| 233-70-12450 | | | C.E. Curv. Carb. | 1 | | | | | | | | | | |
| 233-70-12141 | | | C.E. Curv. Carb. | 1 | | | | | | | | | | |
| GD310RC-3A | | | | | | | | | | | | | | |
| 232-870-6310 | | | C.E. Curv. Carb. | 1 | | | 6,0 | | | 1828 | 6 | 5/8" | | |
| 232-70-12650 | | | C.E. Curv. Carb. | 1 | | | 6,0 | | | 1828 | 7 | 5/8" | | |
| 232-70-12142 | | | C.E. Curv. Carb. | 1 | 6,0 | 1/2 | 6,0 | 152 | 13 | 1828 | 8 | 5/8" | 27,09 | 59,6 |
| 232-70-12130 | 2 | | Moldboard | 2 | 6,0 | 5/8 | 1,5 | 152 | 16 | 465 | 5 | 5/8" | 8,482 | 18,7 |
| GD31RC-3A | | | | | | | | | | | | | | |
| 233-70-12450 | | | C.E. Curv. Carb. | 1 | | | | | | | | | | |
| 233-70-12141 | | | C.E. Curv. Carb. | 1 | | | | | | | | | | |
| 232-70-12150 | | | Overlay | 3 | 9,1 | 1/2 | 1,4 | 230 | 13 | 421 | 5 | 5/8" | 9,441 | 20,8 |
| 232-70-12160 | | | Overlay | 3 | 9,1 | 1/2 | 1,4 | 230 | 13 | 421 | 5 | 5/8" | 9,441 | 20,8 |
| 233-70-12150 | | | | | | | | | | | | | | |
| 233-70-12160 | | | | | | | | | | | | | | |
| GD37-6H | | | | | | | | | | | | | | |
| 232-70-52910 | | | C.E. Curv. Carb. | 1 | | | | | | | | | | |
| 232-70-52970 | | | C.E. Curv. Carb. | 1 | | | | | | | | | | |
| 232-70-52940 | | | C.E. Curv. Carb. | 1 | | | | | | | | | | |
| 232-70-12651 | | | C.E. Curv. Carb. | 1 | | | | | | | | | | |
| 232-70-12131 | | | C.E. Curv. Carb. | 1 | | | | | | | | | | |
| 232-70-12150 | | | Overlay | 3 | 9,1 | 1/2 | 1,4 | 230 | 13 | 421 | 5 | 5/8" | 9,441 | 20,8 |
| 232-70-12160 | | | Overlay | 3 | 9,1 | 1/2 | 1,4 | 230 | 13 | 421 | 5 | 5/8" | 9,441 | 20,8 |
| GD405A-1 | | | | | | | | | | | | | | |
| 233-70-12450 | | | C.E. Curv. Carb. | 1 | | | | | | | | | | |
| 233-70-12141 | | | C.E. Curv. Carb. | 1 | | | | | | | | | | |
| 232-70-52191 | | | Overlay | 3 | | | | | | | | | | |
| 232-70-12150 | | | Overlay | 3 | 9,1 | 1/2 | 1,4 | 230 | 13 | 421 | 5 | 5/8" | 9,441 | 20,8 |
| 232-70-12160 | | | Overlay | 3 | 9,1 | 1/2 | 1,4 | 230 | 13 | 421 | 5 | 5/8" | 9,441 | 20,8 |

KOMATSU-GRADERS

Cutting Edges, Molboards & Overlays



**T O U G H
C O M P O N E N T S**

| O.E.M. Part Nr. | No Pcs | MTM Nr. | Description | Ref. | Inches | | | Millimeters | | | Nr. H. | Ø | Weight | |
|------------------------------|-----------|-------------|------------------|------|--------|-----|-----|-------------|----|------|-----------|------|--------|------|
| | | | | | W | T | L | W | T | L | | | Kg. | Lbs |
| GD40HT-2 | | | | | | | | | | | | | | |
| 234-70-12580 | | | C.E. Curv. Carb. | 1 | | | 6,0 | | | 1828 | 8 | 5/8" | | |
| 234-70-12193 | | 002-R00-01S | C.E. Curv. Carb. | 1 | 6,0 | 5/8 | 6,0 | 152 | 16 | 1828 | 8 | 5/8" | 33,34 | 73,4 |
| 232-70-52910 | | | C.E. Curv. Carb. | 1 | | | 6,0 | | | 1828 | 8 | 5/8" | | |
| 232-70-52970 | | | C.E. Curv. Carb. | 1 | | | 6,0 | | | 1828 | 8 | 5/8" | | |
| 232-70-12651 | | | C.E. Curv. Carb. | 1 | | | 6,0 | | | 1828 | 8 | 5/8" | | |
| 232-70-12143 | | 002-R00-02S | C.E. Curv. Carb. | 1 | 6,0 | 5/8 | 6,0 | 152 | 16 | 1828 | 8 | 5/8" | 33,34 | 73,4 |
| 234-70-12234 | | | | | | | | | | | | | | |
| 234-70-12214 | 2 | 002-708-X27 | Moldboard | 2 | 6,0 | 5/8 | 1,8 | 152 | 16 | 553 | 5 | 5/8" | 10,09 | 22,2 |
| GD500R-1 | | | | | | | | | | | | | | |
| 232-870-6310 | | | C.E. Curv. Carb. | | | | 6,0 | | | 1828 | 8 | 5/8" | | |
| 232-70-12142 | | | C.E. Curv. Carb. | | 6,0 | 1/2 | 6,0 | 152 | 13 | 1828 | 8 | 5/8" | 27,09 | 59,6 |
| 232-70-12650 | | | C.E. Curv. Carb. | | | | | | | | | | | |
| 232-70-12130 | 2 | | Moldboard | 2 | | | | | | | | | | |
| 232-70-12150 | 2 | | Overlay | 3 | 9,1 | 1/2 | 1,4 | 230 | 13 | 421 | 5 | 5/8" | 9,441 | 20,8 |
| 232-70-12160 | 2 | | Overlay | 3 | 9,1 | 1/2 | 1,4 | 230 | 13 | 421 | 5 | 5/8" | 9,441 | 20,8 |
| GD505A-2 | | | | | | | | | | | | | | |
| 232-70-52910 | | | C.E. Curv. Carb. | | | | 6,0 | | | 1828 | 8 | 5/8" | | |
| 232-70-52970 | | | C.E. Curv. Carb. | | | | 6,0 | | | 1828 | 8 | 5/8" | | |
| 232-70-52940 | | | C.E. Curv. Carb. | | | | 6,0 | | | 1828 | 8 | 5/8" | | |
| 232-70-12651 | | | C.E. Curv. Carb. | | | | 6,0 | | | 1828 | 8 | 5/8" | | |
| 232-70-52191 | | | Overlay | 3 | | | | | | | | | | |
| GD505R-2 | | | | | | | | | | | | | | |
| 232-70-52910 | | | C.E. Curv. Carb. | | | | 6,0 | | | 1828 | 8 | 5/8" | | |
| 232-70-52970 | | | C.E. Curv. Carb. | | | | 6,0 | | | 1828 | 8 | 5/8" | | |
| 232-70-52940 | | | C.E. Curv. Carb. | | | | 6,0 | | | 1828 | 8 | 5/8" | | |
| 232-70-12651 | | | C.E. Curv. Carb. | | | | 6,0 | | | 1828 | 8 | 5/8" | | |
| 232-70-12143 | | 002-R00-02S | C.E. Curv. Carb. | | 6,0 | 5/8 | 6,0 | 152 | 16 | 1828 | 8 | 5/8" | 33,34 | 73,4 |
| 232-70-52191 | | | Overlay | 3 | | | | | | | | | | |
| GD523A-1 GD525A-1 | | | | | | | | | | | | | | |
| 232-70-12143 | 2 | 002-R00-02S | C.E. Curv. Carb. | 1 | 6,0 | 5/8 | 6,0 | 152 | 16 | 1828 | 8 | 5/8" | 33,34 | 73,4 |
| 232-70-52190 | 2 | 002-757-X28 | Overlay | 3 | 9,3 | 1/2 | 1,6 | 235 | 13 | 487 | 6 | 3/4" | 11,16 | 24,5 |

KOMATSU-GRADERS

Cutting Edges, Molboards & Overlays



**T O U G H
C O M P O N E N T S**

| O.E.M. Part Nr. | No Pcs | MTM Nr. | Description | Ref. | Inches | | | Millimeters | | | Nr. H. | Ø | Weight | |
|--------------------|-----------|-------------|------------------|------|--------|-----|-----|-------------|----|------|-----------|------|--------|------|
| | | | | | W | T | L | W | T | L | | | Kg. | Lbs |
| GD600R-3 | | | | | | | | | | | | | | |
| 232-70-52910 | | | C.E. Curv. Carb. | 1 | | | | | | | | | | |
| 232-70-52970 | | | C.E. Curv. Carb. | 1 | | | | | | | | | | |
| 232-70-12651 | | | C.E. Curv. Carb. | 1 | | | | | | | | | | |
| 232-70-52940 | | | C.E. Curv. Carb. | 1 | | | | | | | | | | |
| 232-70-52180 | 2 | 002-707-X26 | Moldboard | 2 | 6,0 | 5/8 | 1,6 | 152 | 16 | 472 | 5 | 5/8" | 8,609 | 18,9 |
| 232-70-52190 | 2 | 002-757-X28 | Overlay | 3 | 9,3 | 1/2 | 1,6 | 235 | 13 | 487 | 6 | 3/4" | 11,16 | 24,5 |
| GD605A-3 | | | | | | | | | | | | | | |
| 232-70-52910 | | | C.E. Curv. Carb. | | | | | | | | | | | |
| 232-70-52970 | | | C.E. Curv. Carb. | | | | | | | | | | | |
| 232-70-52940 | | | C.E. Curv. Carb. | | | | | | | | | | | |
| 232-70-12651 | | | C.E. Curv. Carb. | | | | | | | | | | | |
| 232-70-52190 | 2 | 002-757-X28 | Overlay | 3 | 9,3 | 1/2 | 1,6 | 235 | 13 | 487 | 6 | 3/4" | 11,16 | 24,5 |
| 232-70-52180 | 2 | 002-707-X26 | Moldboard | 2 | 6,0 | 5/8 | 1,6 | 152 | 16 | 472 | 5 | 5/8" | 8,609 | 18,9 |
| GD605R-3 | | | | | | | | | | | | | | |
| 232-70-12143 | | 002-R00-02 | C.E. Curv. Carb. | | 6,0 | 5/8 | 6,0 | 152 | 16 | 1828 | 8 | 5/8" | 33,34 | 73,4 |
| 232-70-12651 | | | C.E. Curv. Carb. | | | | | | | 1828 | 8 | 5/8" | | |
| 232-70-52940 | | | C.E. Curv. Carb. | | | | | | | 1828 | 8 | 5/8" | | |
| 232-70-52970 | | | C.E. Curv. Carb. | | | | | | | 1828 | 8 | 5/8" | | |
| 232-70-52910 | | | C.E. Curv. Carb. | | | | | | | 1828 | 8 | 5/8" | | |
| 232-70-52190 | 2 | 002-757-X28 | Overlay | 3 | 9,3 | 1/2 | 1,6 | 235 | 13 | 487 | 6 | 3/4" | 11,16 | 24,5 |
| 232-70-52180 | 2 | 002-707-X26 | Moldboard | 2 | 6,0 | 5/8 | 1,6 | 152 | 16 | 472 | 5 | 5/8" | 8,609 | 18,9 |
| GD623A-1 | | | | | | | | | | | | | | |
| 232-70-12143 | | 002-R00-02S | C.E. Curv. Carb. | | 6,0 | 5/8 | 6,0 | 152 | 16 | 1828 | 8 | 5/8" | 33,34 | 73,4 |
| 232-70-52190 | 2 | 002-757-X28 | Overlay | 3 | 9,3 | 1/2 | 1,6 | 235 | 13 | 487 | 6 | 3/4" | 11,16 | 24,5 |
| 232-70-52180 | 2 | 002-707-X26 | Moldboard | 2 | 6,0 | 5/8 | 1,6 | 152 | 16 | 472 | 5 | 5/8" | 8,609 | 18,9 |
| GD625A-1 | | | | | | | | | | | | | | |
| 232-70-12143 | 2 | 002-R00-02S | C.E. Curv. Carb. | | 6,0 | 5/8 | 6,0 | 152 | 16 | 1828 | 8 | 5/8" | 33,34 | 73,4 |
| 232-70-52180 | 2 | 002-707-X26 | Moldboard | 2 | 6,0 | 5/8 | 1,6 | 152 | 16 | 472 | 5 | 5/8" | 8,609 | 18,9 |
| 232-70-52190 | 2 | 002-757-X28 | Overlay | 3 | 9,3 | 1/2 | 1,6 | 235 | 13 | 487 | 6 | 3/4" | 11,16 | 24,5 |
| GD650R-3 | | | | | | | | | | | | | | |
| 232-70-52910 | | | C.E. Curv. Carb. | | | | | | | | | | | |
| 232-70-52970 | | | C.E. Curv. Carb. | | | | | | | | | | | |
| 232-70-52940 | | | C.E. Curv. Carb. | | | | | | | | | | | |
| 232-70-12651 | | | C.E. Curv. Carb. | | | | | | | | | | | |
| 232-70-52190 | 2 | 002-757-X28 | Overlay | 3 | 9,3 | 1/2 | 1,6 | 235 | 13 | 487 | 6 | 3/4" | 11,16 | 24,5 |
| 232-70-52180 | 2 | 002-707-X26 | Moldboard | 2 | 6,0 | 5/8 | 1,6 | 152 | 16 | 472 | 5 | 5/8" | 8,609 | 18,9 |

KOMATSU-GRADERS

Cutting Edges, Molboards & Overlays



**T O U G H
C O M P O N E N T S**

| O.E.M. Part Nr. | No Pcs | MTM Nr. | Description | Ref. | Inches | | | Millimeters | | | Nr. H. | Ø | Weight | |
|--------------------|-----------|-------------|------------------|------|--------|-----|-----|-------------|----|------|-----------|------|--------|-------|
| | | | | | W | T | L | W | T | L | | | Kg. | Lbs |
| GD655A-3 | | | | | | | | | | | | | | |
| 232-70-12143 | | 002-R00-02S | C.E. Curv. Carb. | | 6,0 | 5/8 | 6,0 | 152 | 16 | 1828 | 8 | 5/8" | 33,34 | 73,4 |
| 232-70-12651 | | | C.E. Curv. Carb. | | | | 6,0 | | | 1828 | 8 | 5/8" | | |
| 232-70-52940 | | | C.E. Curv. Carb. | | | | 6,0 | | | 1828 | 8 | 5/8" | | |
| 232-70-52970 | | | C.E. Curv. Carb. | | | | 6,0 | | | 1828 | 8 | 5/8" | | |
| 232-70-52910 | | | C.E. Curv. Carb. | | | | 6,0 | | | 1828 | 8 | 5/8" | | |
| 232-70-52190 | 2 | 002-757-X28 | Overlay | 3 | 9,3 | 1/2 | 1,6 | 235 | 13 | 487 | 6 | 3/4" | 11,16 | 24,5 |
| 232-70-52180 | 2 | 002-707-X26 | Moldboard | 2 | 6,0 | 5/8 | 1,6 | 152 | 16 | 472 | 5 | 5/8" | 8,609 | 18,9 |
| GD655R-3 | | | | | | | | | | | | | | |
| 232-70-12143 | 1 | 002-R00-02S | C.E. Curv. Carb. | 1 | 6,0 | 5/8 | 6,0 | 152 | 16 | 1828 | 8 | 5/8" | 33,34 | 73,4 |
| 234-70-12193 | 1 | 002-R00-01S | C.E. Curv. Carb. | 1 | 6,0 | 5/8 | 7,0 | 152 | 16 | 2133 | 8 | 5/8" | 38,91 | 85,6 |
| 232-70-52190 | 2 | 002-757-X28 | Overlay | 3 | 9,3 | 1/2 | 1,6 | 235 | 13 | 487 | 6 | 3/4" | 11,16 | 24,5 |
| 232-70-52180 | 2 | 002-707-X26 | Moldboard | 2 | 6,0 | 5/8 | 1,6 | 152 | 16 | 472 | 5 | 5/8" | 8,609 | 18,9 |
| GD705A-3 | | | | | | | | | | | | | | |
| 234-70-12250 | | | C.E. Curv. Carb. | | | | 7,0 | | | 2133 | 9 | 3/4" | | |
| 234-70-32240 | 2 | 02-758-X30 | Overlay | 2 | 11,0 | 1/2 | 2,0 | 280 | 13 | 612 | 6 | 3/4" | 16,71 | 36,8 |
| 234-70-32230 | 2 | 02-709-X29 | Moldboard | 2 | 8,0 | 5/8 | 1,6 | 203 | 16 | 501 | 6 | 3/4" | 12,2 | 26,8 |
| GD705A-4 | | | | | | | | | | | | | | |
| 234-70-32620 | 2 | | C.E. Curv. Carb. | 1 | | | 8,0 | | | 2438 | 9 | 3/4" | | |
| 234-70-16420 | 2 | | C.E. Curv. Carb. | 1 | | | 8,0 | | | 2438 | 9 | 3/4" | | |
| 234-70-16410 | 2 | | C.E. Curv. Carb. | 1 | | | 8,0 | | | 2438 | 9 | 3/4" | | |
| 234-70-16290 | 2 | | C.E. Curv. Carb. | 1 | | | 8,0 | | | 2438 | 9 | 3/4" | | |
| 234-70-16130 | 2 | | C.E. Curv. Carb. | 1 | | | 8,0 | | | 2438 | 9 | 3/4" | | |
| 234-70-12550 | 2 | 002-R00-05S | C.E. Curv. Carb. | 1 | 8,0 | 5/8 | 7,0 | 203 | 16 | 2133 | 9 | 3/4" | 51,96 | 114,3 |
| 234-70-32440 | | | | | | | | | | | | | | |
| 234-70-32330 | | | | | | | | | | | | | | |
| 234-70-32240 | 2 | 002-758-X30 | Overlay | 2 | 11,0 | 1/2 | 2,0 | 280 | 13 | 612 | 6 | 3/4" | 16,71 | 36,8 |
| 234-70-32230 | 2 | 002-709-X29 | Moldboard | 2 | 8,0 | 5/8 | 1,6 | 203 | 16 | 501 | 6 | 3/4" | 12,2 | 26,8 |
| GD705R-2 | | | | | | | | | | | | | | |
| 234-70-12640 | | | C.E. Curv. Carb. | 1 | | | 7,0 | | | 2133 | | | | |
| 234-70-12233 | 2 | 002-759-X31 | Overlay | 3 | 9,3 | 1/2 | 1,7 | 235 | 13 | 530 | 6 | 5/8" | 12,14 | 26,7 |
| GD725A-1 | | | | | | | | | | | | | | |
| 234-70-12710 | | 002-R00-05S | C.E. Curv. Carb. | | 8,0 | 5/8 | 7,0 | 203 | 16 | 2133 | 9 | 3/4" | 51,96 | 114,3 |
| 234-70-32240 | 2 | 002-758-X30 | Overlay | 2 | 11,0 | 1/2 | 2,0 | 280 | 13 | 612 | 6 | 3/4" | 16,71 | 36,8 |
| 234-70-32230 | 2 | 002-709-X29 | Moldboard | 2 | 8,0 | 5/8 | 1,6 | 203 | 16 | 501 | 6 | 3/4" | 12,2 | 26,8 |

KOMATSU-GRADERS

Cutting Edges, Molboards & Overlays



**T O U G H
C O M P O N E N T S**

| O.E.M. Part Nr. | No Pcs | MTM Nr. | Description | Ref. | Inches | | | Millimeters | | | Nr. H. | Ø | Weight | |
|------------------------------------|-----------|-------------|------------------|------|--------|-----|-----|-------------|----|------|-----------|------|--------|-------|
| | | | | | W | T | L | W | T | L | | | Kg. | Lbs |
| GD825A-1 GD825A-2 | | | | | | | | | | | | | | |
| 235-70-12140 | | | C.E. Curv. Carb. | | 8,0 | 3/4 | 8,0 | 203 | 19 | 2438 | 10 | 3/4" | 70,53 | 155,2 |
| 234-70-32440 | | | | | | | 8,0 | | | 2438 | 10 | 3/4" | | |
| 234-70-32330 | | | | | | | 8,0 | | | 2438 | 10 | 3/4" | | |
| 234-70-32240 | 2 | 002-758-X30 | Overlay | 2 | 11,0 | 1/2 | 2,0 | 280 | 13 | 612 | 6 | 3/4" | 16,71 | 36,8 |
| 234-70-32230 | 2 | 002-709-X29 | Moldboard | 2 | 8,0 | 5/8 | 1,6 | 203 | 16 | 501 | 6 | 3/4" | 12,2 | 26,8 |

KOMATSU-GRADERS

Curved Carbon Steel Blades, Moldboards & Overlays



**TOUGH
COMPONENTS**

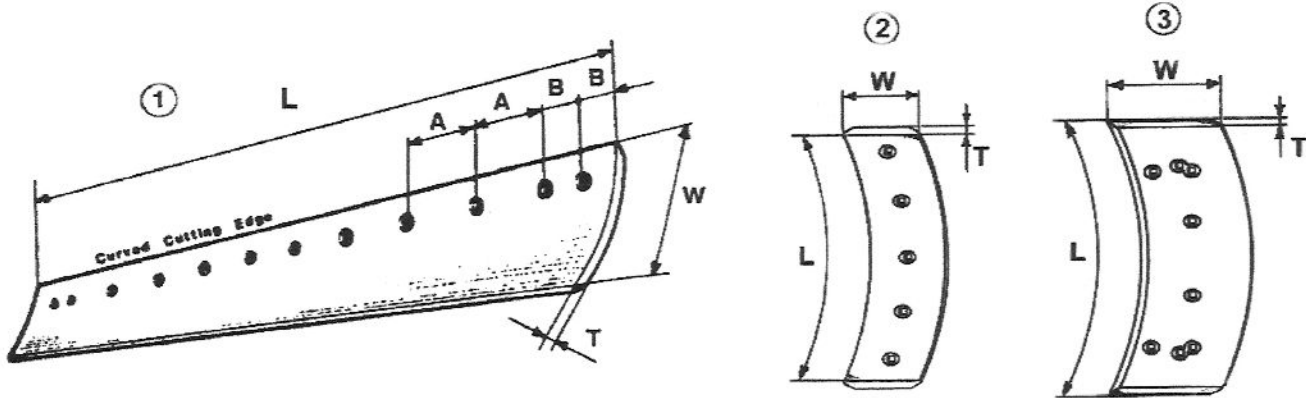

| O.E.M. Part Nr. | MTM Part Nr. | Description | Ref. | Inches (O.E.M.) | | | Millimeters | | | A | B | Hls. Nr. | Ø | Weight | |
|--|-----------------|-------------|------|-----------------|----|----|-------------|-----|------|-----|----|-------------|------|--------|------|
| | | | | T | W | L | T | W | L | | | | | Kg. | Lbs |
| Size 1/2 - 6" 13 - 152 mm | | | | | | | | | | | | | | | |
| | 001-R001-90S | C.E. Carbon | 1 | 1/2" | 6" | 4' | 16 | 152 | 1219 | 12" | 3" | 6 | 5/8" | 22,2 | 48,9 |
| 233-70-12141S | 001-R001-29S | C.E. Carbon | 1 | 1/2" | 6" | 5' | 16 | 152 | 1524 | 12" | 3" | 7 | 5/8" | 27,8 | 61,2 |
| 232-70-12142S | 001-R001-15S | C.E. Carbon | 1 | 1/2" | 6" | 6' | 16 | 152 | 1828 | 12" | 3" | 8 | 5/8" | 33,3 | 73,4 |
| 234-70-12192S | 001-R001-16S | C.E. Carbon | 1 | 1/2" | 6" | 7' | 16 | 152 | 2133 | 12" | 3" | 9 | 5/8" | 38,9 | 85,6 |
| | 001-R001-35S | C.E. Carbon | 1 | 1/2" | 6" | 8' | 16 | 152 | 2438 | 12" | 3" | 10 | 5/8" | 44,5 | 97,8 |
| | 001-R02-02S | C.E. Carbon | 1 | 1/2" | 6" | 4' | 16 | 152 | 1219 | 12" | 3" | 6 | 3/4" | 22,2 | 48,9 |
| | 001-R02-06S | C.E. Carbon | 1 | 1/2" | 6" | 5' | 16 | 152 | 1524 | 12" | 3" | 7 | 3/4" | 27,8 | 61,2 |
| | 001-R001-4S1 | C.E. Carbon | 1 | 1/2" | 6" | 6' | 16 | 152 | 1828 | 12" | 3" | 8 | 3/4" | 33,3 | 73,4 |
| | 001-R001-42S | C.E. Carbon | 1 | 1/2" | 6" | 7' | 16 | 152 | 2133 | 12" | 3" | 9 | 3/4" | 38,9 | 85,6 |
| | 001-R001-39S | C.E. Carbon | 1 | 1/2" | 6" | 8' | 16 | 152 | 2438 | 12" | 3" | 10 | 3/4" | 44,5 | 97,8 |
| Size 5/8 - 6" 16 - 152 mm | | | | | | | | | | | | | | | |
| | 001-R001-90S | C.E. Carbon | 1 | 5/8" | 6" | 4' | 16 | 152 | 1219 | 12" | 3" | 6 | 5/8" | 22,2 | 48,9 |
| 238-70-12220 | 001-R001-29S | C.E. Carbon | 1 | 5/8" | 6" | 5' | 16 | 152 | 1524 | 12" | 3" | 7 | 5/8" | 27,8 | 61,2 |
| 232-70-12143 | 001-R001-15S | C.E. Carbon | 1 | 5/8" | 6" | 6' | 16 | 152 | 1828 | 12" | 3" | 8 | 5/8" | 33,3 | 73,4 |
| 234-70-12193 | 001-R001-16S | C.E. Carbon | 1 | 5/8" | 6" | 7' | 16 | 152 | 2133 | 12" | 3" | 9 | 5/8" | 38,9 | 85,6 |
| | 001-R001-35S | C.E. Carbon | 1 | 5/8" | 6" | 8' | 16 | 152 | 2438 | 12" | 3" | 10 | 5/8" | 44,5 | 97,8 |
| | 001-R02-02S | C.E. Carbon | 1 | 5/8" | 6" | 4' | 16 | 152 | 1219 | 12" | 3" | 6 | 3/4" | 22,2 | 48,9 |
| | 001-R02-06S | C.E. Carbon | 1 | 5/8" | 6" | 5' | 16 | 152 | 1524 | 12" | 3" | 7 | 3/4" | 27,8 | 61,2 |
| | 001-R001-41S | C.E. Carbon | 1 | 5/8" | 6" | 6' | 16 | 152 | 1828 | 12" | 3" | 8 | 3/4" | 33,3 | 73,4 |

KOMATSU-GRADERS

Curved Carbon Steel Blades, Moldboards & Overlays



**T O U G H
C O M P O N E N T S**

| O.E.M. Part Nr. | MTM Part Nr. | Description | Ref. | Inches (O.E.M.) | | | Millimeters | | | A | B | Hls. Nr. | Ø | Weight | |
|--|-----------------|-------------|------|-----------------|----|----|-------------|-----|------|-----|----|-------------|------|--------|-------|
| | | | | T | W | L | T | W | L | | | | | Kg. | Lbs |
| Size 5/8 - 6" 16 - 152 mm | | | | | | | | | | | | | | | |
| | 001-R001-42S | C.E. Carbon | 1 | 5/8" | 6" | 7' | 16 | 152 | 2133 | 12" | 3" | 9 | 3/4" | 38,9 | 85,6 |
| | 001-R001-39S | C.E. Carbon | 1 | 5/8" | 6" | 8' | 16 | 152 | 2438 | 12" | 3" | 10 | 3/4" | 44,5 | 97,8 |
| Size 3/4 - 6" 19 - 152 mm | | | | | | | | | | | | | | | |
| | 001-R02-03S | C.E. Carbon | 1 | 3/4" | 6" | 4' | 19 | 152 | 1219 | 12" | 3" | 6 | 5/8" | 26,4 | 58,1 |
| | 001-R001-06S | C.E. Carbon | 1 | 3/4" | 6" | 5' | 19 | 152 | 1524 | 12" | 3" | 7 | 5/8" | 33,0 | 72,6 |
| | 001-R001-17S | C.E. Carbon | 1 | 3/4" | 6" | 6' | 19 | 152 | 1828 | 12" | 3" | 8 | 5/8" | 39,6 | 87,1 |
| | 001-R001-18S | C.E. Carbon | 1 | 3/4" | 6" | 7' | 19 | 152 | 2133 | 12" | 3" | 9 | 5/8" | 46,2 | 101,6 |
| | 001-R02-10S | C.E. Carbon | 1 | 3/4" | 6" | 8' | 19 | 152 | 2438 | 12" | 3" | 10 | 5/8" | 52,8 | 116,2 |
| | 001-R02-04S | C.E. Carbon | 1 | 3/4" | 6" | 4' | 19 | 152 | 1219 | 12" | 3" | 6 | 3/4" | 26,4 | 58,1 |
| | 001-R02-07S | C.E. Carbon | 1 | 3/4" | 6" | 5' | 19 | 152 | 1524 | 12" | 3" | 7 | 3/4" | 33,0 | 72,6 |
| | 001-R02-08S | C.E. Carbon | 1 | 3/4" | 6" | 6' | 19 | 152 | 1828 | 12" | 3" | 8 | 3/4" | 39,6 | 87,1 |
| | 001-R02-09S | C.E. Carbon | 1 | 3/4" | 6" | 7' | 19 | 152 | 2133 | 12" | 3" | 9 | 3/4" | 46,2 | 101,6 |
| | 001-R02-11S | C.E. Carbon | 1 | 3/4" | 6" | 8' | 19 | 152 | 2438 | 12" | 3" | 10 | 3/4" | 52,8 | 116,2 |
| Size 1/2 - 8" 13 - 203 mm | | | | | | | | | | | | | | | |
| | 001-R001-89S | C.E. Carbon | 1 | 1/2" | 8" | 4' | 16 | 203 | 1219 | 12" | 3" | 6 | 5/8" | 29,7 | 65,3 |
| | 001-R001-30S | C.E. Carbon | 1 | 1/2" | 8" | 5' | 16 | 203 | 1524 | 12" | 3" | 7 | 5/8" | 37,1 | 81,7 |
| | 001-R001-22S | C.E. Carbon | 1 | 1/2" | 8" | 6' | 16 | 203 | 1828 | 12" | 3" | 8 | 5/8" | 44,5 | 98,0 |
| | 001-R001-21S | C.E. Carbon | 1 | 1/2" | 8" | 7' | 16 | 203 | 2133 | 12" | 3" | 9 | 5/8" | 52,0 | 114,3 |
| | 001-R001-23S | C.E. Carbon | 1 | 1/2" | 8" | 8' | 16 | 203 | 2438 | 12" | 3" | 10 | 5/8" | 59,4 | 130,7 |
| | 001-R02-13S | C.E. Carbon | 1 | 1/2" | 8" | 4' | 16 | 203 | 1219 | 12" | 3" | 6 | 3/4" | 29,7 | 65,3 |
| | 001-R02-17S | C.E. Carbon | 1 | 1/2" | 8" | 5' | 16 | 203 | 1524 | 12" | 3" | 7 | 3/4" | 37,1 | 81,7 |
| | 001-R001-47S | C.E. Carbon | 1 | 1/2" | 8" | 6' | 16 | 203 | 1828 | 12" | 3" | 8 | 3/4" | 44,5 | 98,0 |
| | 001-R001-25S | C.E. Carbon | 1 | 1/2" | 8" | 7' | 16 | 203 | 2133 | 12" | 3" | 9 | 3/4" | 52,0 | 114,3 |
| | 001-R001-38S | C.E. Carbon | 1 | 1/2" | 8" | 8' | 16 | 203 | 2438 | 12" | 3" | 10 | 3/4" | 59,4 | 130,7 |
| Size 5/8 - 8" 16 - 203 mm | | | | | | | | | | | | | | | |
| | 001-R001-89S | C.E. Carbon | 1 | 5/8" | 8" | 4' | 16 | 203 | 1219 | 12" | 3" | 6 | 5/8" | 29,7 | 65,3 |
| | 001-R001-30S | C.E. Carbon | 1 | 5/8" | 8" | 5' | 16 | 203 | 1524 | 12" | 3" | 7 | 5/8" | 37,1 | 81,7 |
| | 001-R001-22S | C.E. Carbon | 1 | 5/8" | 8" | 6' | 16 | 203 | 1828 | 12" | 3" | 8 | 5/8" | 44,5 | 98,0 |
| | 001-R001-21S | C.E. Carbon | 1 | 5/8" | 8" | 7' | 16 | 203 | 2133 | 12" | 3" | 9 | 5/8" | 52,0 | 114,3 |

Our parts are not original but they are interchangeable with them. The O.E.M. Part Numbers are give for reference purposes only.

KOMATSU-GRADERS

Curved Carbon Steel Blades, Moldboards & Overlays



**T O U G H
C O M P O N E N T S**

| O.E.M. Part Nr. | MTM Part Nr. | Description | Ref. | Inches (O.E.M.) | | | Millimeters | | | A | B | Hls. Nr. | Ø | Weight | |
|----------------------|-----------------|-------------|------|-----------------|-----|------|-------------|-----|------|-----|----|-------------|------|--------|-------|
| | | | | T | W | L | T | W | L | | | | | Kg. | Lbs |
| Size 5/8 - 8" | | | | | | | | | | | | | | | |
| 16 - 203 mm | | | | | | | | | | | | | | | |
| | 001-R001-23S | C.E. Carbon | 1 | 5/8" | 8" | 8' | 16 | 203 | 2438 | 12" | 3" | 10 | 5/8" | 59,4 | 130,7 |
| | 001-R02-13S | C.E. Carbon | 1 | 5/8" | 8" | 4' | 16 | 203 | 1219 | 12" | 3" | 6 | 3/4" | 29,7 | 65,3 |
| | 001-R02-17S | C.E. Carbon | 1 | 5/8" | 8" | 5' | 16 | 203 | 1524 | 12" | 3" | 7 | 3/4" | 37,1 | 81,7 |
| | 001-R001-47S | C.E. Carbon | 1 | 5/8" | 8" | 6' | 16 | 203 | 1828 | 12" | 3" | 8 | 3/4" | 44,5 | 98,0 |
| 234-70-12710 | 001-R001-25S | C.E. Carbon | 1 | 5/8" | 8" | 7' | 16 | 203 | 2133 | 12" | 3" | 9 | 3/4" | 52,0 | 114,3 |
| | 001-R001-38S | C.E. Carbon | 1 | 5/8" | 8" | 8' | 16 | 203 | 2438 | 12" | 3" | 10 | 3/4" | 59,4 | 130,7 |
| Size 3/4 - 8" | | | | | | | | | | | | | | | |
| 19 - 203 mm | | | | | | | | | | | | | | | |
| | 001-R02-14S | C.E. Carbon | 1 | 3/4" | 8" | 4' | 19 | 203 | 1219 | 12" | 3" | 6 | 5/8" | 35,3 | 77,6 |
| | 001-R001-93S | C.E. Carbon | 1 | 3/4" | 8" | 5' | 19 | 203 | 1524 | 12" | 3" | 7 | 5/8" | 44,1 | 97,0 |
| 232-70-52850 | 001-R001-19S | C.E. Carbon | 1 | 3/4" | 8" | 6' | 19 | 203 | 1828 | 12" | 3" | 8 | 5/8" | 52,9 | 116,3 |
| 234-70-12670 | 001-R001-20S | C.E. Carbon | 1 | 3/4" | 8" | 7' | 19 | 203 | 2133 | 12" | 3" | 9 | 5/8" | 61,7 | 135,7 |
| | 001-R001-24S | C.E. Carbon | 1 | 3/4" | 8" | 8' | 19 | 203 | 2438 | 12" | 3" | 10 | 5/8" | 70,5 | 155,2 |
| | 001-R02-15S | C.E. Carbon | 1 | 3/4" | 8" | 4' | 19 | 203 | 1219 | 12" | 3" | 6 | 3/4" | 35,3 | 77,6 |
| | 001-R02-18S | C.E. Carbon | 1 | 3/4" | 8" | 5' | 19 | 203 | 1524 | 12" | 3" | 7 | 3/4" | 44,1 | 97,0 |
| | 001-R001-26S | C.E. Carbon | 1 | 3/4" | 8" | 6' | 19 | 203 | 1828 | 12" | 3" | 8 | 3/4" | 52,9 | 116,3 |
| | 001-R001-27S | C.E. Carbon | 1 | 3/4" | 8" | 7' | 19 | 203 | 2133 | 12" | 3" | 9 | 3/4" | 61,7 | 135,7 |
| 235-70-12140 | 001-R001-28S | C.E. Carbon | 1 | 3/4" | 8" | 8' | 19 | 203 | 2438 | 12" | 3" | 10 | 3/4" | 70,5 | 155,2 |
| Moldboards | | | | | | | | | | | | | | | |
| 232-70-12130 | | Moldboard | 2 | 5/8" | 6" | 18,3 | 16 | 152 | 465 | | | 5 | 5/8" | 8,5 | 18,7 |
| 232-70-52180 | 002-707-X26 | Moldboard | 2 | 5/8" | 6" | 18,6 | 16 | 152 | 472 | | | 5 | 5/8" | 8,6 | 18,9 |
| 233-70-12150 | | Moldboard | 2 | 5/8" | 6" | 17,8 | 16 | 152 | 451 | | | 4 | 5/8" | 8,2 | 18,1 |
| 233-70-12160 | | Moldboard | 2 | 5/8" | 6" | 17,8 | 16 | 152 | 451 | | | 4 | 5/8" | 8,2 | 18,1 |
| 234-70-12214 | 002-708-X27 | Moldboard | 2 | 5/8" | 6" | 21,8 | 16 | 156 | 553 | | | 5 | 5/8" | 10,4 | 22,8 |
| 234-70-32230 | 002-709-X29 | Moldboard | 2 | 5/8" | 8" | 19,7 | 16 | 203 | 500 | | | 6 | 3/4" | 12,2 | 26,8 |
| 237-870-1120 | | Moldboard | 2 | 5/8" | 6" | 16,7 | 16 | 152 | 423 | | | 4 | 5/8" | 7,7 | 17,0 |
| 237-870-1130 | | Moldboard | 2 | 5/8" | 6" | 16,7 | 16 | 152 | 423 | | | 4 | 5/8" | 7,7 | 17,0 |
| Overlay | | | | | | | | | | | | | | | |
| 232-70-12150 | | Overlay | 3 | 1/2" | 9,3 | 16,6 | 13 | 235 | 421 | | | 5 | 5/8" | 9,6 | 21,2 |
| 232-70-12160 | | Overlay | 3 | 1/2" | 9,3 | 16,6 | 13 | 235 | 421 | | | 5 | 5/8" | 9,6 | 21,2 |
| 232-70-52190 | 002-757-X28 | Overlay | 3 | 1/2" | 9,3 | 19,2 | 13 | 235 | 487 | | | 6 | 3/4" | 11,2 | 24,5 |
| 232-70-52191 | | Overlay | 3 | 1/2" | 9,3 | 23,7 | 13 | 235 | 603 | | | 7 | 5/8" | 13,8 | 30,4 |
| 232-70-52980 | | Overlay | 3 | 1/2" | 9,3 | 23,5 | 13 | 235 | 596 | | | 6 | 5/8" | 13,7 | 30,0 |

Our parts are not original but they are interchangeable with them. The O.E.M. Part Numbers are give for reference purposes only.

KOMATSU-GRADERS

Curved Carbon Steel Blades, Moldboards & Overlays



**T O U G H
C O M P O N E N T S**

| O.E.M. Part Nr. | MTM Part Nr. | Description | Ref. | Inches (O.E.M.) | | | Millimeters | | | A | B | Hls. Nr. | Ø | Weight | |
|--------------------|-----------------|-------------|------|-----------------|------|------|-------------|-----|-----|---|---|-------------|------|--------|------|
| | | | | T | W | L | T | W | L | | | | | Kg. | Lbs |
| Overlay | | | | | | | | | | | | | | | |
| 234-70-12233 | 002-759-X31 | Overlay | 3 | 1/2" | 9,3 | 20,9 | 13 | 235 | 530 | | | 6 | 5/8" | 12,1 | 26,7 |
| 234-70-12650 | | Overlay | 3 | 1/2" | 9,3 | 24,9 | 13 | 235 | 632 | | | 6 | 5/8" | 14,5 | 31,9 |
| 234-70-32240 | 002-758-X30 | Overlay | 3 | 1/2" | 11,0 | 24,1 | 13 | 280 | 612 | | | 6 | 3/4" | 16,7 | 36,8 |
| 237-70-22150 | | Overlay | 3 | 1/2" | 9,3 | 22,0 | 13 | 235 | 558 | | | 7 | 5/8" | 12,8 | 28,1 |